

TRUSTED  
**SINCE 1958**  
WORLDWIDE

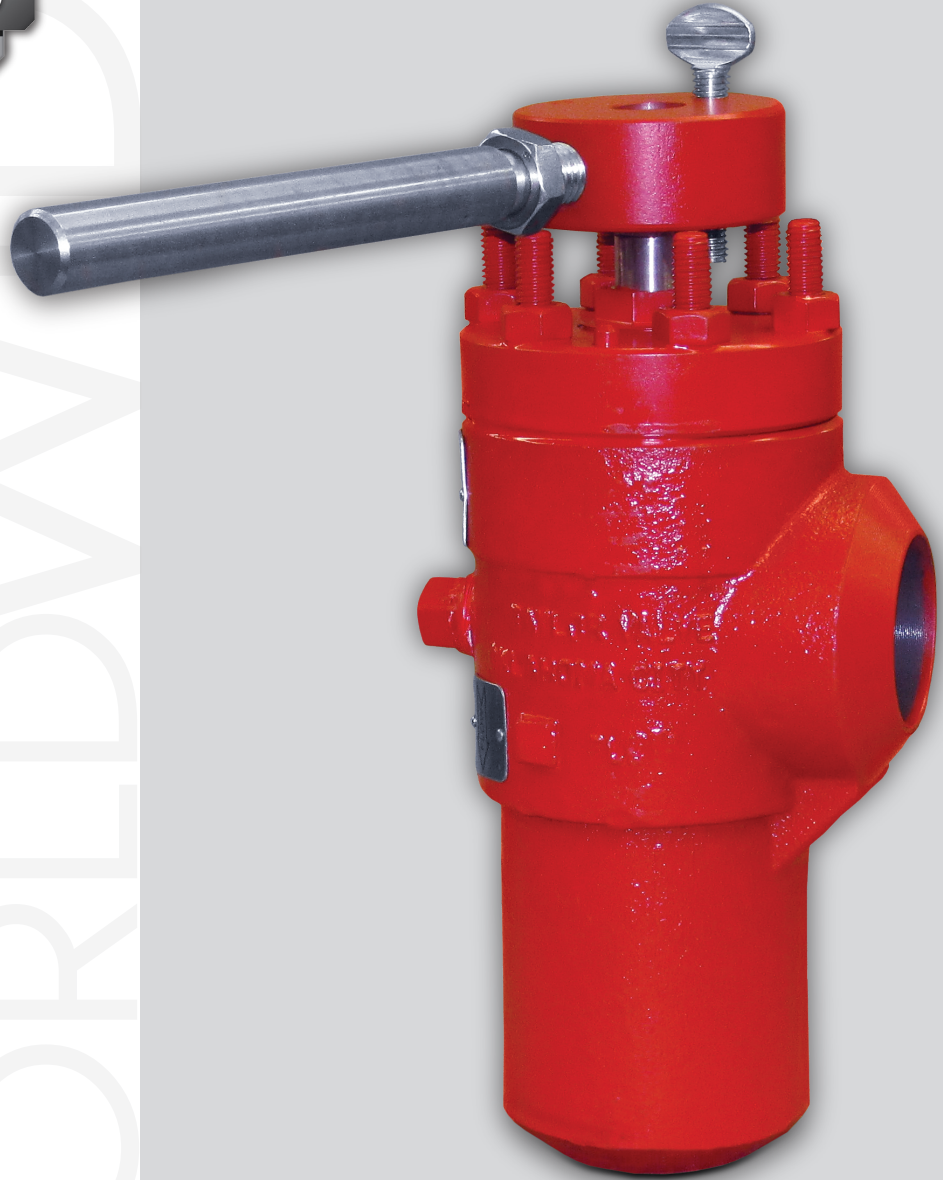

Precise.

---

Quality.

---

Reliable.

---



# MDA / MDAS SERIES CHOKE VALVES

## FEATURES & *Benefits*

Taylor Valve MDA / MDAS Series Chokes are made with wear resistant material to extend service life, with redundant O-Rings on the Bonnet Seals and Stem Seals that help prevent leakage. Fully Guided Stems reduce imbalance and vibration. Control Discs provide ANSI Class III/IV Shut off.

Available sizes are the 1 Inch, 2 Inch, and the 3 Inch chokes.

- Accurate Control - 90 degree rotation from Full Off to Full On.
- Bolted Bonnet - Safety Bonnet is bolted into the body, it avoids the well-known risks of corrosion, cross threading, galling of threaded type connection in production environments.
- Extended Mean Time Between Service - Robust design and liberal application of hardened materials, efficient flow-geometry means the valves offer maximum production potential and minimum service requirements.
- Easy Maintenance - Repair parts can be installed in the field without removing the valve from the line.
- Optional Features - Choke Valves can have trims and actuators custom designed for specific requirements. Such as special noise reduction trims, reduced port and maximum orifice trims, and for very high pressure or minimum pressure loss for a declining field.

### Applications:

- Well Site Automation
- Water Injection Control Valve
- CO2 Injection Control Valve
- Pump Bypass
- Pump Startup
- Gas Lift Injection Control
- High Temperature Protection
- Blow Down and Dump Valve
- Remote Control for directional drilling
- Steam Injection
- Steam Tracer Control
- Manual and Automated Application



Taylor Valve Technology Multi-Orifice Valve Design Principle Provides Precision Control. The two adjacent internal discs each contain two precision orifices.

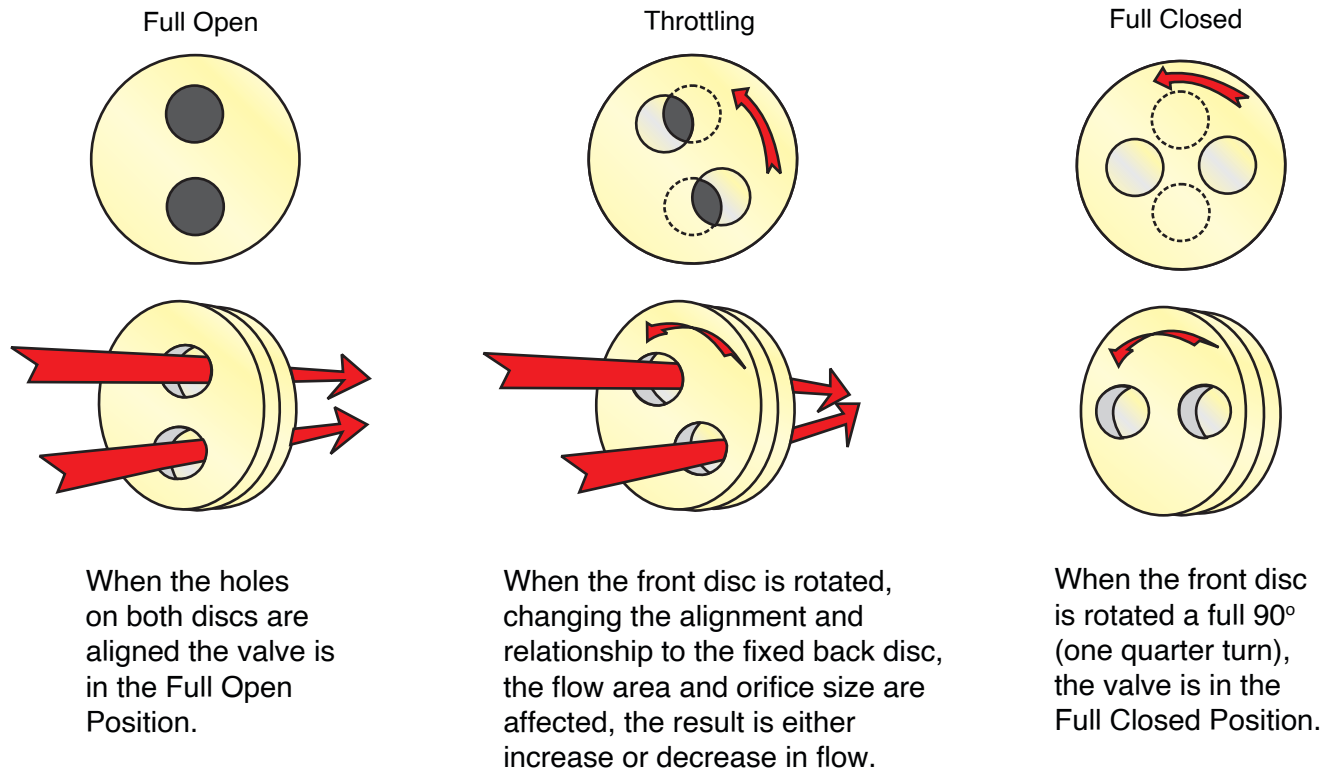

The discs are lapped to within two light bands of flatness (+/- .00002") to achieve positive shut off and maintain precise control. The fixed back disc is held perpendicular to the flow. The front disc floats against the back disc and seeks a mating surface promoting a positive seal. The differential pressure across the upstream disc and the downstream disc stabilizes the control surfaces. Vibration, noise or fatigues normally associated with loose or unsupported parts are eliminated. No control surfaces are introduced into the orifice, providing a clear center line for the flow. The valves are rated for shut-off at ANSI Class III or IV depending on the style of valve and trim used. The orifices of the standard disc expose a small control surface profile to the fluid steam reducing wear. The multi-orifice design produces near linear flow characteristics. The low torque and quarter-turn design of Taylor Valve Technology's Multi-orifice valves allows for a variety of actuation options: manual, pneumatic, hydraulic, or electric.

No.	Description	Qty
1	Body	1
2*	Wear Sleeve	1
3**	Pointer	1
4	Cage	1
5	Dowel Pin	4
6	Disc	2
7	Fork	1
8	Bonnet	1
9	Retainer Wire	1
10**	Dowel Pin	2
11	O-Ring	2
12	O-Ring	1
13	O-Ring	1
14	O-Ring	2
15	Backup Ring	2
16	Thrust Bearing	1
17	Cap Screw	6
18	Index Plate	1
19***	Turning Hub	1
20***	Turning Handle	1
21***	Jam Nut	1
22	Fitting Vent	1
23**	Screw	2
24**	Data Label	1
25**	Thumb Screw	1

\*Item Optional

\*\*Items not shown in section view

\*\*\*Items not included on actuated version

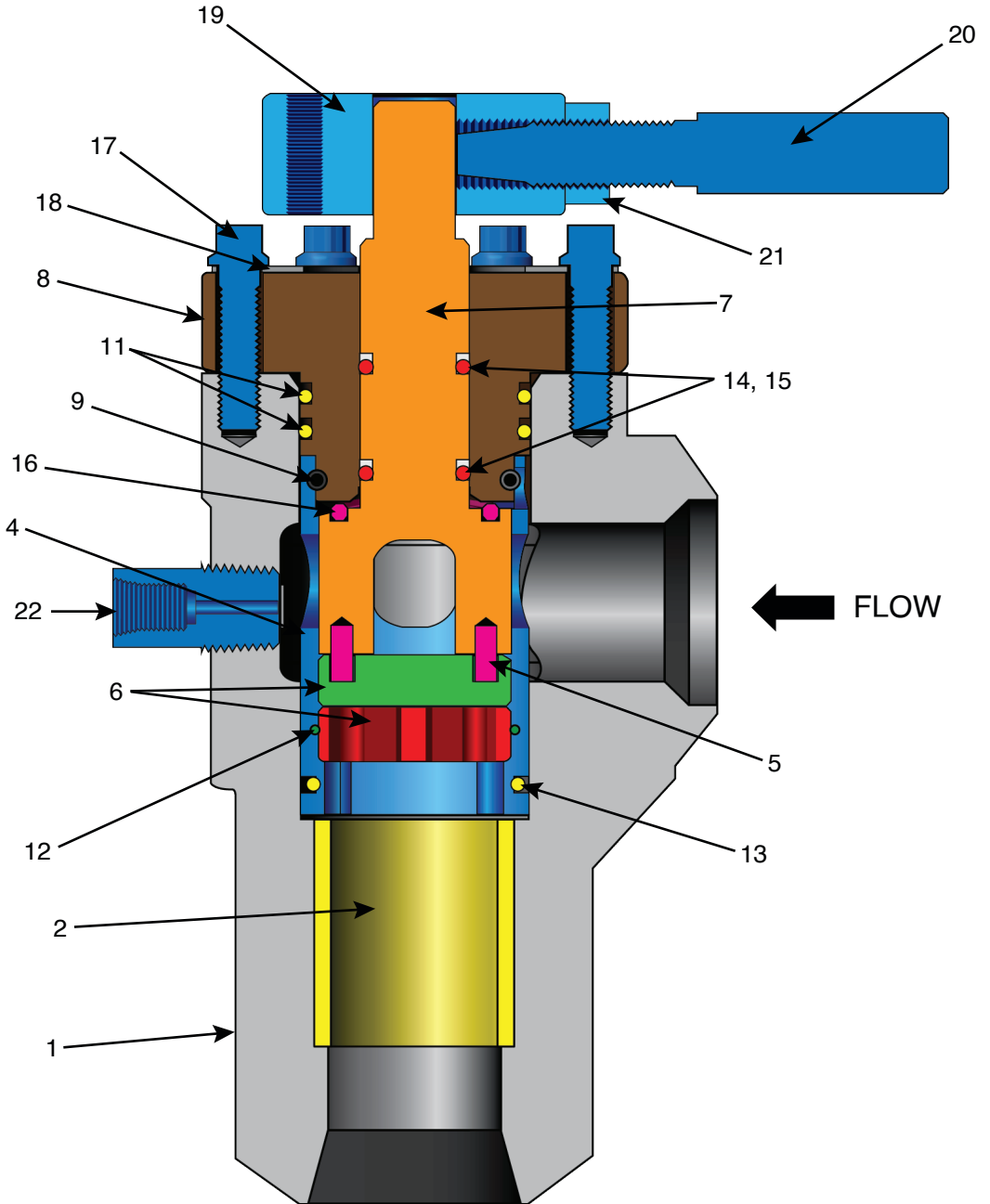

## MDA Angle Choke

1" & 2" Configurations

1018/1020 CS, 316 SS

¼ Turn Actuated

Body Rating = 5,000 PSI

CV Range = 0.7 – 23.86

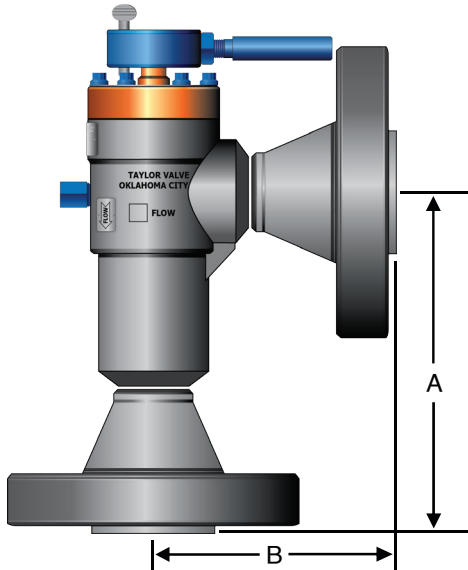

### 1" BODY STANDARD DIMENSIONS AND WEIGHTS

CONNECTIONS		DIM. END-to-END IN. (MM.) +/- .10		WEIGHT	
INLET	OUTLET	A	B	LB.	KG.
1" FNPT	1" FNPT	5.53 (140)	2.80 (71)	23	10.44
1" FNPT	1" FNPT	5.58 (142)	2.74 (70)	23	10.44
1" BUTT WELD	1" BUTT WELD	5.58 (142)	2.74 (70)	22	9.99
1" 150 RFJ	1" 150 RFJ	7.86 (200)	5.02 (128)	28	12.71
1" 150 RTJ	1" 150 RTJ	8.05 (204)	5.21 (132)	28	12.71
1" 300 RFF	1" 300 RFF	8.11 (206)	5.27 (134)	30	13.62
1" 300 RTJ	1" 300 RTJ	8.30 (211)	5.46 (139)	30	13.62
1" 600 RFF	1" 600 RFF	8.36 (212)	5.52 (140)	30	13.62
1" 600 RTJ	1" 600 RTJ	8.36 (212)	5.52 (140)	30	13.62
1" 900/1500 RFF	1" 900/1500 RFF	8.80 (224)	5.96 (151)	40	18.16
1" 900/1500 RTJ	1" 900/1500 RTJ	8.80 (224)	5.96 (151)	40	18.16
1" 2500 RFF	1" 2500 RFF	9.42 (239)	6.58 (167)	46	20.88
1" 2500 RTJ	1" 2500 RTJ	9.42 (239)	6.58 (167)	46	20.88

### 2" BODY STANDARD DIMENSIONS AND WEIGHTS

CONNECTIONS		DIM. END-to-END IN. (MM.) +/- .10		WEIGHT	
INLET	OUTLET	A	B	LB.	KG.
2" FNPT	2" FNPT	5.58 (142)	2.74 (70)	22	9.99
2" BUTT WELD	2" BUTT WELD	5.58 (142)	2.74 (70)	22	9.99
2" 150 RFJ	2" 150 RFJ	8.17 (208)	5.33 (135)	33	14.98
2" 150 RTJ	2" 150 RTJ	8.36 (212)	5.52 (140)	33	14.98
2" 300 RFF	2" 300 RFF	8.42 (214)	5.58 (142)	39	17.71
2" 300 RTJ	2" 300 RTJ	8.67 (220)	5.83 (148)	39	17.71
2" 600 RFF	2" 600 RFF	8.80 (224)	5.96 (151)	45	20.43
2" 600 RTJ	2" 600 RTJ	8.86 (225)	6.02 (153)	45	20.43
2" 900/1500 RFF	2" 900/1500 RFF	9.92 (252)	7.08 (180)	72	32.69
2" 900/1500 RTJ	2" 900/1500 RTJ	9.98 (253)	7.14 (181)	72	32.69
2" 2500 RFF	2" 2500 RFF	10.92 (277)	8.08 (205)	106	48.12
2" 2500 RTJ	2" 2500 RTJ	10.98 (279)	8.14 (207)	106	48.12
2-1/16" 3000 API	2-1/16" 3000 API	9.98 (253)	7.14 (181)	74	33.60
2-1/16" 5000 API	2-1/16" 5000 API	9.98 (253)	7.14 (181)	76	34.50
2-9/16" 3000 API	2-9/16" 3000 API	10.11 (257)	7.27 (185)	94	42.68
2-9/16" 5000 API	2-9/16" 5000 API	10.11 (257)	7.27 (185)	96	43.58

The information contained in these drawings is the sole property of Taylor Valve Technology Inc. and any reproduction in part or whole without the written permission of Taylor Valve Technology Inc. is prohibited.

NOTE: Taylor Valve reserves the right to change product designs and specifications without notice.

No.	Description	Qty
1	Body	1
2*	Wear Sleeve	1
3**	Pointer	1
4	Cage	1
5	Dowel Pin	4
6	Disc	2
7	Fork	1
8	Bonnet	1
9	Crush Seal	1
10	Retainer Wire	1
11**	Dowel Pin	2
12	Hex Nut	6
13	O-Ring	1
14	Crush Seal	1
15	Hi-Temp Packing	2
16	Hex Gland Nut	2
17	Thrust Bearing	1
18	Stud	6
19	Index Plate	1
20***	Turning Hub	1
**21***	Turning Handle	1
**22***	Jam Nut	1
23	Fitting Vent	1
24**	Screw	2
25**	Data Label	1
26**	Thumb Screw	1

\*Item Optional

\*\*Items not shown in section view

\*\*\*Items not included on actuated version

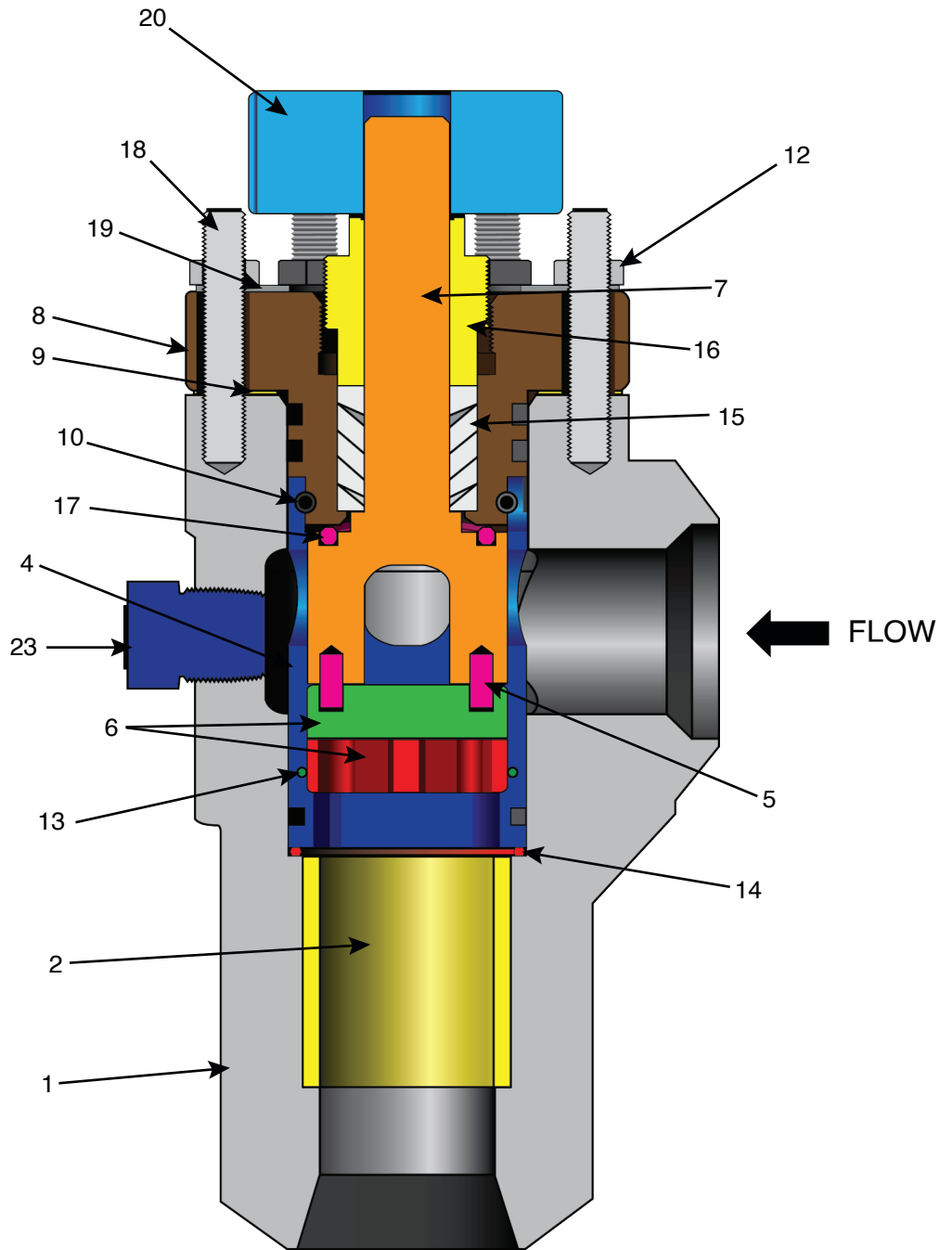

## MDAS Angle Choke

1" & 2" Configurations

1018/1020 CS, 316 SS

¼ Turn Actuated

Body Rating = 5,000 PSI/

MAWP 1333 PSI for steam

CV Range = 0.7 – 23.86

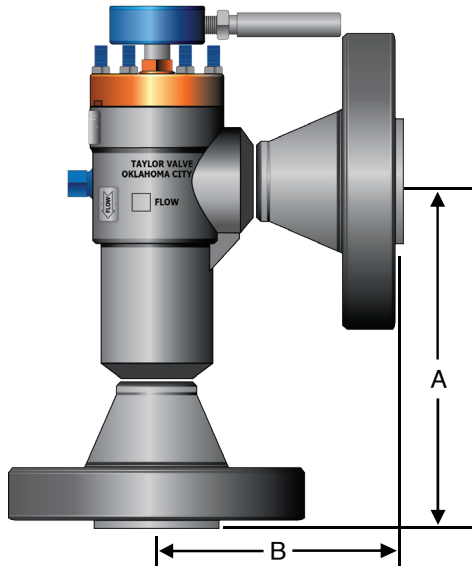

1" BODY STANDARD DIMENSIONS AND WEIGHTS					
CONNECTIONS		DIM. END-to-END IN. (MM.) +/- .10		WEIGHT	
INLET	OUTLET	A	B	LB.	KG.
1" FNPT	1" FNPT	5.53 (140)	2.80 (71)	23	10.44
1" FNPT	1" FNPT	5.58 (142)	2.74 (70)	23	10.44
1" BUTT WELD	1" BUTT WELD	5.58 (142)	2.74 (70)	22	9.99
1" 150 RFJ	1" 150 RFJ	7.86 (200)	5.02 (128)	28	12.71
1" 150 RTJ	1" 150 RTJ	8.05 (204)	5.21 (132)	28	12.71
1" 300 RFF	1" 300 RFF	8.11 (206)	5.27 (134)	30	13.62
1" 300 RTJ	1" 300 RTJ	8.30 (211)	5.46 (139)	30	13.62
1" 600 RFF	1" 600 RFF	8.36 (212)	5.52 (140)	30	13.62
1" 600 RTJ	1" 600 RTJ	8.36 (212)	5.52 (140)	30	13.62
1" 900/1500 RFF	1" 900/1500 RFF	8.80 (224)	5.96 (151)	40	18.16
1" 900/1500 RTJ	1" 900/1500 RTJ	8.80 (224)	5.96 (151)	40	18.16
1" 2500 RFF	1" 2500 RFF	9.42 (239)	6.58 (167)	46	20.88
1" 2500 RTJ	1" 2500 RTJ	9.42 (239)	6.58 (167)	46	20.88

2" BODY STANDARD DIMENSIONS AND WEIGHTS					
CONNECTIONS		DIM. END-to-END IN. (MM.) +/- .10		WEIGHT	
INLET	OUTLET	A	B	LB.	KG.
2" FNPT	2" FNPT	5.58 (142)	2.74 (70)	22	9.99
2" BUTT WELD	2" BUTT WELD	5.58 (142)	2.74 (70)	22	9.99
2" 150 RFJ	2" 150 RFJ	8.17 (208)	5.33 (135)	33	14.98
2" 150 RTJ	2" 150 RTJ	8.36 (212)	5.52 (140)	33	14.98
2" 300 RFF	2" 300 RFF	8.42 (214)	5.58 (142)	39	17.71
2" 300 RTJ	2" 300 RTJ	8.67 (220)	5.83 (148)	39	17.71
2" 600 RFF	2" 600 RFF	8.80 (224)	5.96 (151)	45	20.43
2" 600 RTJ	2" 600 RTJ	8.86 (225)	6.02 (153)	45	20.43
2" 900/1500 RFF	2" 900/1500 RFF	9.92 (252)	7.08 (180)	72	32.69
2" 900/1500 RTJ	2" 900/1500 RTJ	9.98 (253)	7.14 (181)	72	32.69
2" 2500 RFF	2" 2500 RFF	10.92 (277)	8.08 (205)	106	48.12
2" 2500 RTJ	2" 2500 RTJ	10.98 (279)	8.14 (207)	106	48.12
2-1/16" 3000 API	2-1/16" 3000 API	9.98 (253)	7.14 (181)	74	33.60
2-1/16" 5000 API	2-1/16" 5000 API	9.98 (253)	7.14 (181)	76	34.50
2-9/16" 3000 API	2-9/16" 3000 API	10.11 (257)	7.27 (185)	94	42.68
2-9/16" 5000 API	2-9/16" 5000 API	10.11 (257)	7.27 (185)	96	43.58

# Choke Nomenclature

Choke Series
CA
CI
MC
MCX
MDA
MDAS
MDI
MDIS
RB
RBHU (Hammer Union)

Size
1 1"
2 2"
3 3"
4 4"
6 6"

Service Type
0 Standard
1 NACE
2 Steam/High Temp.

Style
0 Non-flanged
1 RFF
2 RTJ
3 RFF X RTJ
4 RTJ X RFF
5 NPT X API

Trim Material
03 CARBIDE DISC - STELLITE WR SLV
04 CERAMIC DISC - STELLITE WR SLV
05 CARBIDE DISC - CARBIDE WR SLV
15 CERAMIC DISC - NO WR SLV
16 CARBIDE DISC - NO WR SLV
32 CERAMIC DISC/CARBIDE FLOW TUBE
44 R/RB-SERIES
47 BEAN 17-4 SS
17 CARBIDE DISCS & DIFFUSER
18 CERAMIC DISCS & DIFFUSER

Actuation Type
0 Manual Handle
1 Manual Gear
2 Electric
3 Pneumatic
4 Hydraulic
7 Positive Bean

Schedule
0 Non-flanged
1 40
2 80
3 160
4 XS
5 XXS
6 SLIP-ON
7 API
8 120
9 XXH X S80
A S80 X S40
B NPT X API
C S120 X S80

Body Material
00 DUPLEX SS
03 CARBON STEEL
04 LOW ALLOY (4130 LACS)
05 316 SS (CF8M)
06 316 SS "L" (CF3M)
07 ALUMINUM BRONZE
08 A350 LF2
09 LCC
10 INCONEL
11 SUPER DUPLEX SS
12 440 SS
13 410 SS

**MDA** - **2** **0** **0** **17** **17** **1** **2** **04** **05** **03** **04** = MDA-20017171204050304  
**MDAS** - **2** **2** **0** **17** **17** **1** **2** **04** **05** **03** **07** = MDAS-22017171204050307  
**EXAMPLE ONLY\***

Choke part number has to be 17 digits.

Inlet Connection		Outlet Connection	
01 1" FNPT	41	6" 600	
02 1" BUTT WELD	42	6" 900	
03 1" SOCKET WELD	43	6" 1500	
04 1" VICTAULIC	44	6" 2500	
05 1" 150	45	8" 150	
06 1" 300	46	8" 300	
07 1" 600	47	8" 600	
08 1" 900/1500	48	8" 900	
09 1" 2500	49	8" 1500	
10 2" FNPT	50	8" 2500	
12 2" BUTT WELD	51	2-1/16" 3000	
13 2" SOCKET WELD	52	2-1/16" 5000	
14 2" VICTAULIC	53	2-1/16" 10000	
15 2" 150	54	2-9/16" 3000	
16 2" 300	55	2-9/16" 5000	
17 2" 600	56	2-9/16" 10000	
18 2" 900/1500	57	3-1/8" 3000	
19 2" 2500	58	3-1/8" 5000	
20 3" FNPT	59	3-1/8" 10000	
21 3" BUTT WELD	60	4-1/16" 3000	
22 3" SOCKET WELD	61	4-1/16" 5000	
23 3" 150	62	1-13/16" 10000	
24 3" 300	63	3-1/16" 5000	
25 3" 600	64	3/4" 600#	
26 3" 900	65	1.5" 900/1500	
27 3" 1500	66	3-1/16" 10000	
28 3" 2500	67	7-1/16" 5000	
29 4" FNPT	68	1-13/16" 15000	
30 4" BUTT WELD	69	2-1/16" 15000	
31 4" SOCKET WELD	75	1" UNION	
32 4" VICTAULIC	76	3" 602M x 3" 602F Union	
33 4" 150	78	3-1/16" 15000	
34 4" 300	80	10" 600	
35 4" 600	81	10" 900	
36 4" 900	82	10" 1500	
37 4" 1500	83	10" 2500	
38 4" 2500	84	2-9/16" 15000	
39 6" 150	85	6" Butt Weld	
40 6" 300	87	1.5" 1500	

Orifice Size	
01 (2) 1/8" RND PORTS	29 48/64 BEAN
02 (2) 3/16" RND PORTS	34 32/64 BEAN
03 (2) 1/4" RND PORTS	43 40/64 BEAN
04 (2) 3/8" RND PORTS	44 34/64 BEAN
05 (2) 1/2" RND PORTS	45 28/64 BEAN
06 (2) 5/8" PIE PORTS	46 30/64 BEAN
07 (2) 3/4" RND PORTS	53 10/64 BEAN
08 (2) 7/8" RND PORTS	63 11/64 BEAN
10 (2) 1-3/16" RND PORTS	64 14/64 BEAN
11 (2) 1-1/4" RND PORTS	65 15/64 BEAN
14 (2) 1-1/2" RND PORTS	66 16/64 BEAN
30 (2) 3/4" PIE PORTS	67 19/64 BEAN
32 (2) 1-3/4" RND PORTS	68 20/64 BEAN
35 (2) 1" ROUND PORTS	69 24/64 BEAN
38 (2) 2" PIE PORTS	70 21/64 BEAN
40 (2) 1-1/4" PIE PORTS	71 22/64 BEAN
41 (2) 1-3/8" PIE PORTS	72 23/64 BEAN
42 (2) 1-1/8" RND PORTS	73 27/64 BEAN
47 (2) 1-1/2" PIE PORTS	74 29/64 BEAN
49 (2) 5/8" RND PORTS	75 25/64 BEAN
54 (2) 2.92" PIE HOLES	76 1/7" RND PORTS
55 3 CV	77 7/64 BEAN
56 12 CV	78 54/64 BEAN
57 164 CV	79 44/64 BEAN
58 420 CV	80 45/64 BEAN
59 64 CV	81 47/64 BEAN
60 35 CV	82 51/64 BEAN
22 17/64 BEAN	83 35/64 BEAN
23 18/64 BEAN	84 37/64 BEAN
24 8/64 BEAN	85 6 CV
25 13/64 BEAN	86 85 CV
26 4/64 BEAN	87 12/64 BEAN
27 38/64 BEAN	88 78 CV
28 36/64 BEAN	89 42/64 BEAN
	90 43/64 BEAN
	91 41/64 BEAN

Seal Material	
00 HNBR/HSN	
01 NBR	
03 EPDM	
04 FKM (VITON)	
05 NEOPRENE	
06 NBR (PEROXIDE CURED)	
07 STEAM SEALS	
09 AFLAS	
11 V8588	
12 KALREZ 7075	

PINS	
I INCONEL (Optional)	

Butt weld connections MUST specify a schedule.  
 All API connections are "RTJ" style by default.  
 API flange bore (SCHEDULE) is specified by API.

**Taylor Valve Technology**  
 8300 S.W. 8th Street  
 Oklahoma City, Oklahoma 73128  
  
**TEL** 405.787.0145  
**FAX** 800.805.3401  
**WEB** www.taylorvalve.com  
**EMAIL** info@taylorvalve.com

\*See back page of actual choke product brochure for a more detailed order number example.  
 \*For more options, contact Taylor Valve.

REVISED: 06-10-21



**Taylor Valve Technology**  
 8300 S.W. 8th Street  
 Oklahoma City, Oklahoma 73128

**TEL** 405.787.0145  
**FAX** 800.805.3401

**WEB** www.taylorvalve.com  
**EMAIL** info@taylorvalve.com